

## Inside clamping beveling machine US 150

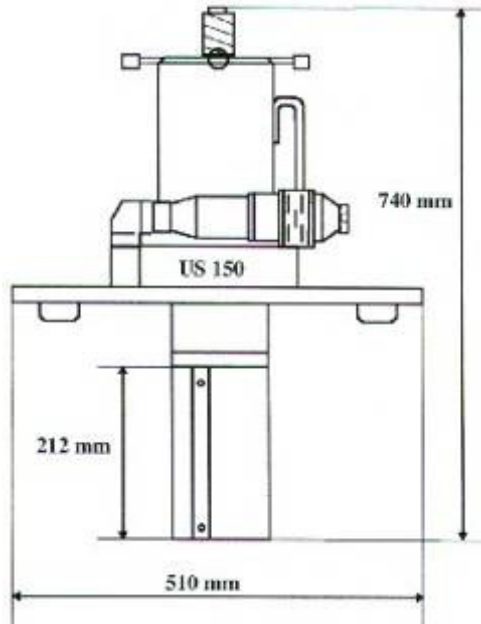

**machining capacity:**

150 mm ID – 508 mm OD

**clamping capacity:**

150 mm ID – 508 mm ID

**bevel forms:**

Facing, 30 and 37°30 bevel, J-bevel, others on request

**clamping:**

manual with key

**Expansion:**

30 mm

**feed stroke:** 100 mm

**cutting head gear drive:**

7 - 10 rpm off-load speed, 5 - 7 rpm nominal speed

Machine is delivered with:

- 1 tool holder plate
- 4 tool bit holders
- sets of clamping blades for above mentioned diameters
- 1 tool bit 90°, 1 tool bit 30°
- key and screws
- operating manual