

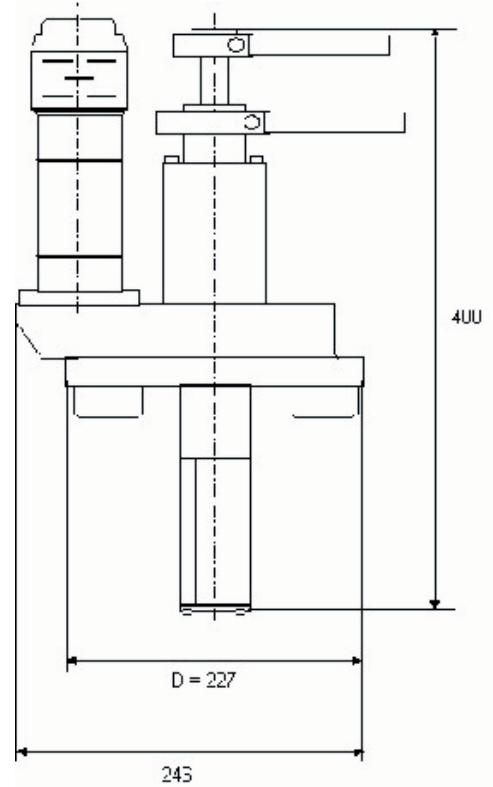

Inside clamping beveling machine type US40

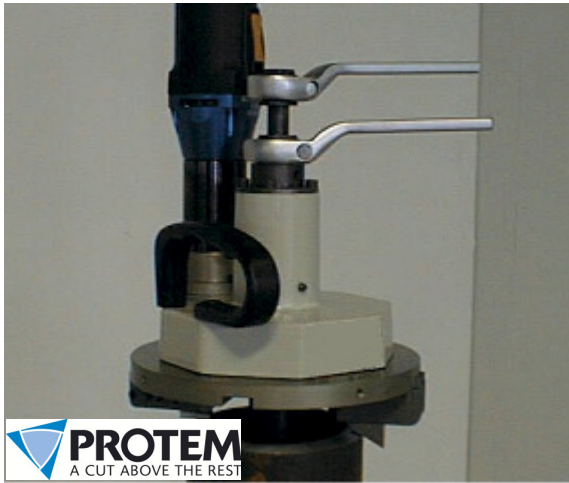

machining capacity:

43 mm ID – 219 mm OD

clamping capacity:

43 mm ID – 219 mm ID

bevel forms:

Facing, 30 and 37°30 bevel, J-bevel, others on request

clamping:

manual with ratchet

Expansion:

16 mm

feed stroke:

with ratchet

cutting head gear drive:

25 rpm off-load speed, 16 rpm nominal speed