



Inside clamping and beveling machine type US80



machining capacity:

80 mm ID – 360 mm OD

clamping capacity:

80 mm ID – 355 mm ID

bevel forms:

Facing, 30 and 37°30 bevel, J-bevel, others on request

clamping:

manual with key

Expansion:

25 mm

feed stroke:

60 mm

cutting head gear drive:

16 rpm off-load speed, 11 rpm nominal speed

Picture with option dual drive

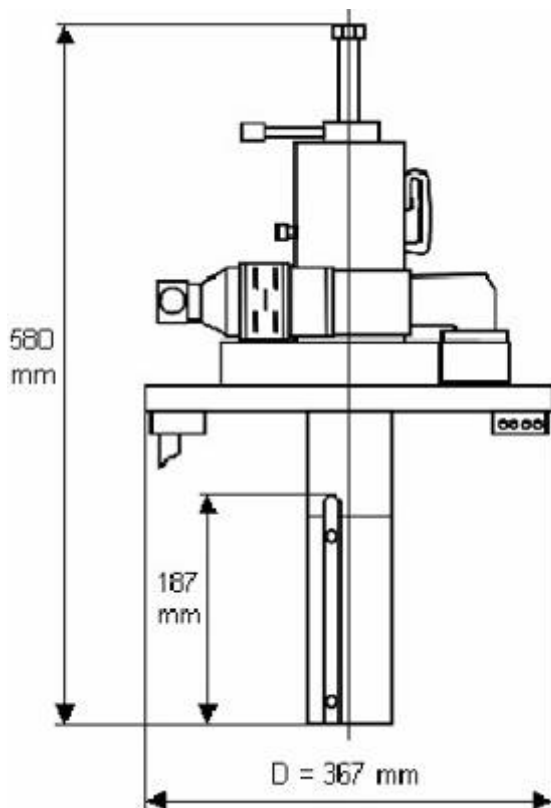

US80 with flange facing attachment